

Anti-Ligature Sensor Faucet

FEATURES:

- Vandal resistant, sensor activation
- Sensor, solenoid, batteries, and temperature can all be accessed from above the counter
- 0.5 gpm flow rate
- Fits standard 4" centerset
- Programmed vandal protection maximum run time of 60 seconds
- Operating range of 20 to 80 psi
- Power supply: 3 AA batteries in battery case

STANDARDS:

- ADA compliant
- ASME A112.18.1/CSA B125.1 certified
- NSF/ANSI 372 certified
- NSF/ANSI 61 certified

WARRANTY:

Visit www.speakman.com for full product warranty information

- See Speakman.com For Warranty Information



Information continues on next page

All dimensions are in inches (in millimeters) unless otherwise specified and are subject to change without notice.

Architect/Engineer Approval Space:

P: 800-537-2107
F: 800-977-2747
W: WWW.SPEAKMAN.COM
R: 01-SEPTEMBER 2024

Anti-Ligature Sensor Faucet

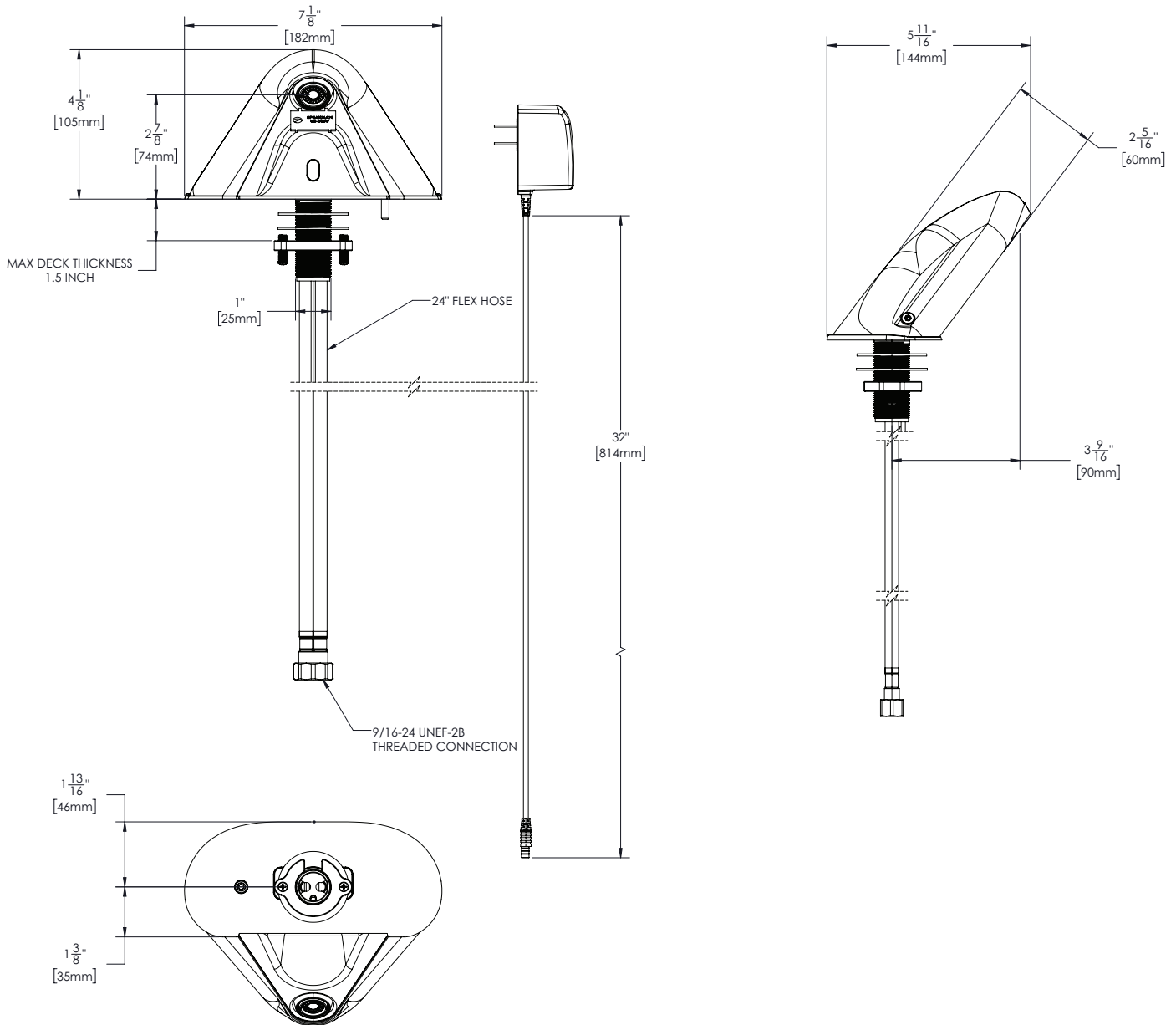

All dimensions are in inches (millimeters) unless otherwise specified and are subject to change without notice.

Architect/Engineer Approval Space:

P: 800-537-2107
F: 800-977-2747
W: WWW.SPEAKMAN.COM
R: 01-SEPTEMBER 2024