

Gravityflo® Freeze Protected Jacket

FEATURES:

- For use with SE-4300
- Water-resistant insulating jacket keeps water tepid down to -10 °F (-23 °C)
- Heater: 120 VAC/3amps; 200W heating pads, includes ground fault plug with reset
- LCD temperature readout

STANDARDS:

- UL499/CSA B22.2 certified

WARRANTY:

Visit www.speakman.com for full product warranty information

- 3 Year Limited Warranty (commercial)



Information continues on next page

All dimensions are in inches (millimeters) unless otherwise specified and are subject to change without notice.

Architect/Engineer Approval Space:

P: 800-537-2107
F: 800-977-2747
W: WWW.SPEAKMAN.COM
R: 02-NOVEMBER 2019

Gravityflo® Freeze Protected Jacket

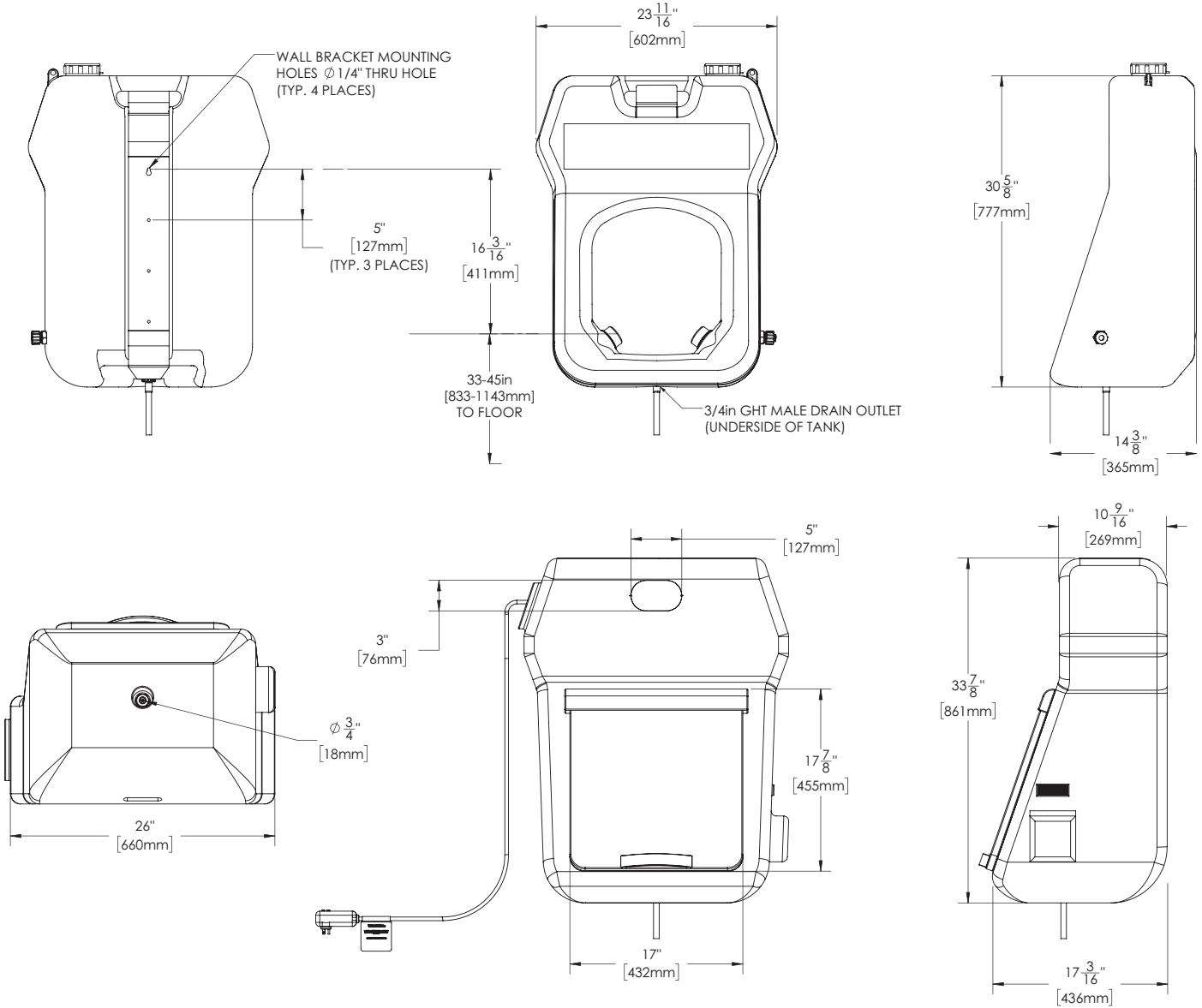

All dimensions are in inches (millimeters) unless otherwise specified and are subject to change without notice.

Architect/Engineer Approval Space:

P: 800-537-2107
 F: 800-977-2747
 W: WWW.SPEAKMAN.COM
 R: 02-NOVEMBER 2019