

## INSTALLATION INSTRUCTIONS

### T-5002 Two-Piece Elongated Toilet



92-T-5002-02

## TOOLS & SUPPLIES NEEDED

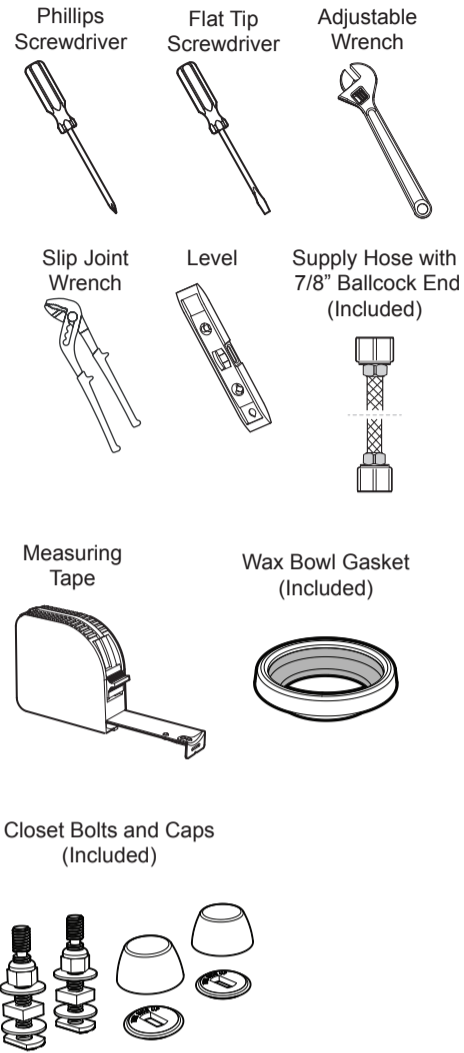

## IMPORTANT

### SAFETY TIPS:

Be sure to read and understand all instructions before beginning installation. Inspect all connections after installation. Be sure to wear proper eye protection.

### MAINTENANCE:

Your new Speakman Product is designed for years of trouble-free performance. Keep it looking new by cleaning it periodically with a soft cloth. Avoid abrasive cleaners, steel wool, and harsh chemicals as these will dull the finish and void your warranty.

Your new Speakman Toilet includes a premium fill valve with an internal filter designed to trap impurities allowing for reliable operation of the fill valve. Periodic removal and cleaning of the filter is recommended for optimal performance. Please see the "Fill Valve Filter Cleaning" section of this document for more information.

### NOTE:

This installation manual covers several models of Toilets. While the appearance of your Toilet may differ from those shown, the installation method is the same.

## ⚠ WARNING

**DO NOT OVER-TIGHTEN CONNECTIONS OR DAMAGE MAY OCCUR.**

**DO NOT USE CHLORINE OR ANY CHEMICALLY RELATED COMPONENTS AS THIS WILL RESULT IN DAMAGE TO TANK COMPONENTS AND MAY CAUSE FLOODING AND PROPERTY DAMAGE.**

**USE OF CHLORINE OR CHEMICALLY RELATED COMPONENTS WILL VOID WARRANTY.**

**NEED HELP?**  
For additional assistance or service please contact:



800-537-2107



www.speakman.com

## VERIFY ROUGH-IN

- 1** For your Toilet to fit correctly, the rough-in distance between the finished wall to the center of the Closet Flange must be at least 12"

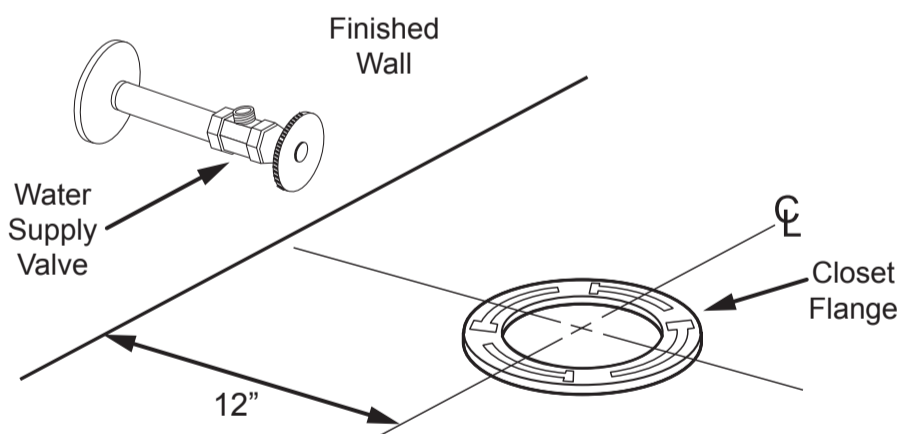

## PREPARING THE TANK

- 2** Place the Toilet Tank upside down onto padding. Inspect the pre-installed Fill Valve Nut and Flush Valve Nut for a secure connection.

**Fill Valve Nut:** Hand tighten only!

**Flush Valve Nut:** Hand tighten, then wrench tighten 1/2 turn.

Place the Tank-to-Bowl Gasket onto the Flush Valve Nut. While pressing down, spread the Gasket over the Nut until the Gasket touches the bottom of the Tank.

**Note:** A small gap between the Tank Bottom and Gasket is allowable.

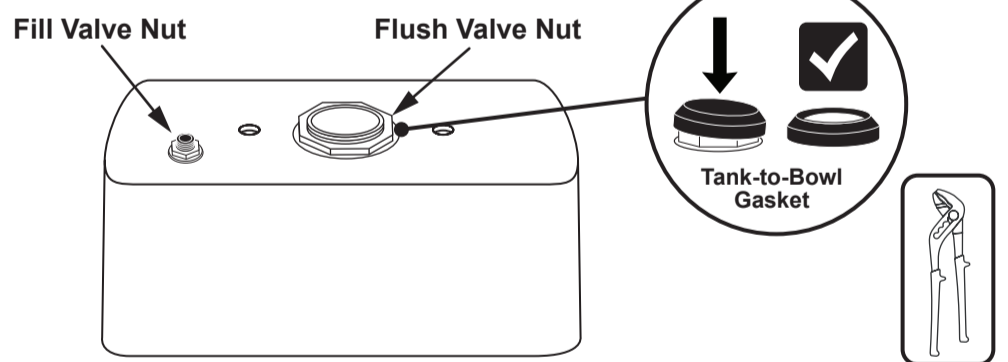

## INSTALL SUPPLY LINE TO TANK

- 3** Install Water Supply Line to the Inlet Shank of the Fill Valve. Tighten into position. **Do Not Over-Tighten** connection or damage may occur.

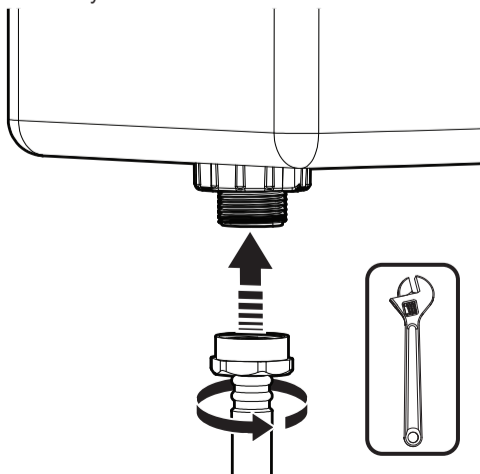

**DRY CONNECTION ONLY!**

DO NOT USE ANY THREAD SEALANT ON THIS CONNECTION

## INSTALL TANK BOLTS

- 4** Install the Conical Rubber Washers onto Tank Bolts with the tapered side facing down. Reach inside the Tank and position the Tank Bolts through the Bolt Holes in the bottom of the Tank. From below the Tank, install a set of Rubber Washers, Metal Washers, Lock Washers, and Nuts. Wrench tighten.

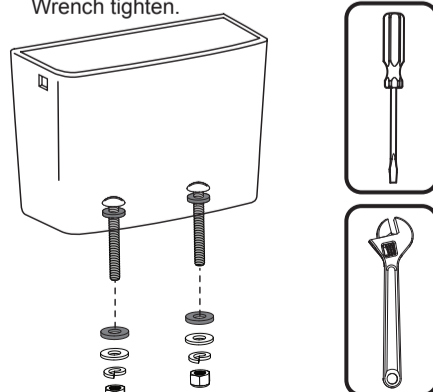

**CAUTION:** Do not over-tighten or damage may occur.

## SECURING THE TANK TO THE BOWL

- 5** Position Tank above Bowl and guide Tank Bolt Assemblies through the appropriate holes in the Bowl. From below, install a 2<sup>nd</sup> set of Metal Washers, Lock Washers, and Nuts to secure the Tank to the Bowl. Wrench tighten until Tank makes several points of contact to the bowl.

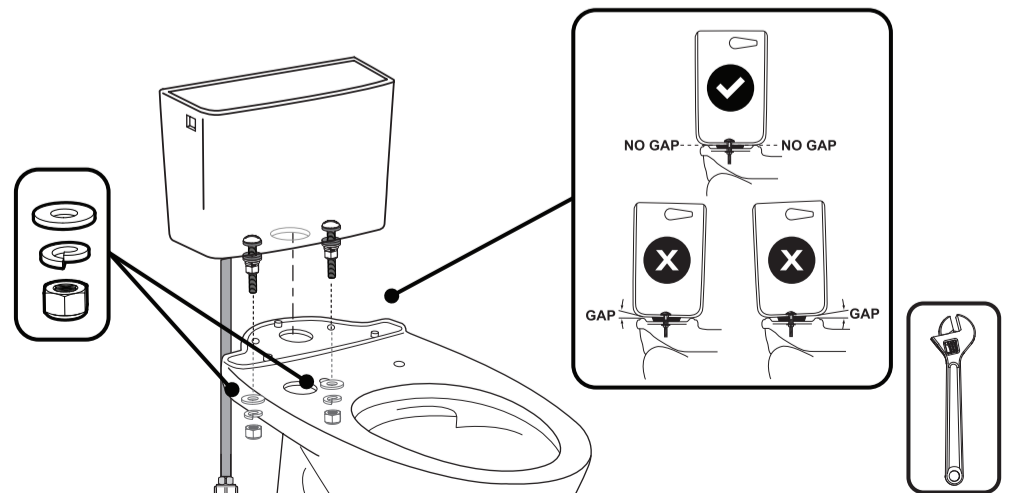

**CAUTION:** Do not over-tighten or damage may occur.

## WAX RING INSTALL

- 6** Carefully lay the Toilet down on its back onto some padding. Firmly press a Bowl Wax Ring onto the circular recess around the Toilet Bowl's Horn.

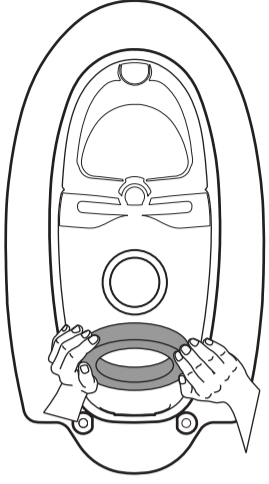

## CLOSET BOLT INSTALL

- 7** Clean any debris out of the Closet Flange and then install new Closet Bolts into the slots of the Closet Flange. The head of the bolt should be inserted into the slot with its threads facing upward as shown. Once the Closet Bolts are located properly, secure into position with a Washer and Square Nut. Wrench tighten.

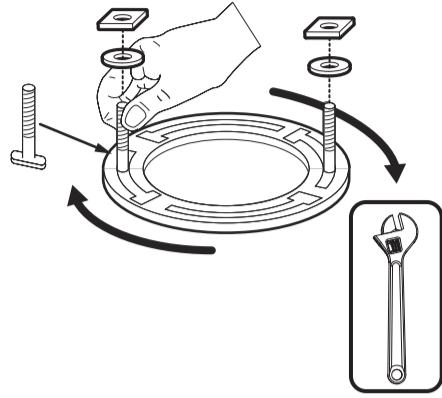

## POSITION TOILET ONTO WAX RING

- 8** Turn the Toilet upright and gently lower into position over the Closet Flange and Closet Bolts. With the Toilet properly aligned, firmly press on both sides of Toilet Rim to set the Bowl Wax Ring. Ensure Toilet is properly aligned.

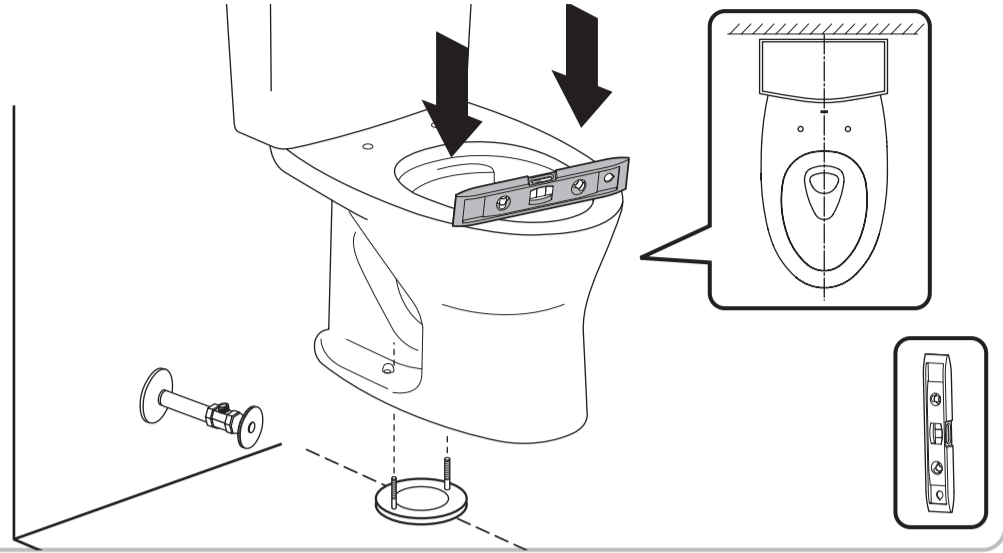

## SECURE BOWL INTO POSITION

- 9** **CAUTION:** Do not move the Bowl after the Bowl Wax Ring is set. Position a Base Cap and Flat Washer over the Closet Bolt. Secure into position with a Brass Acorn Nut. Tighten evenly until the Bowl is snug to the Closet Flange.

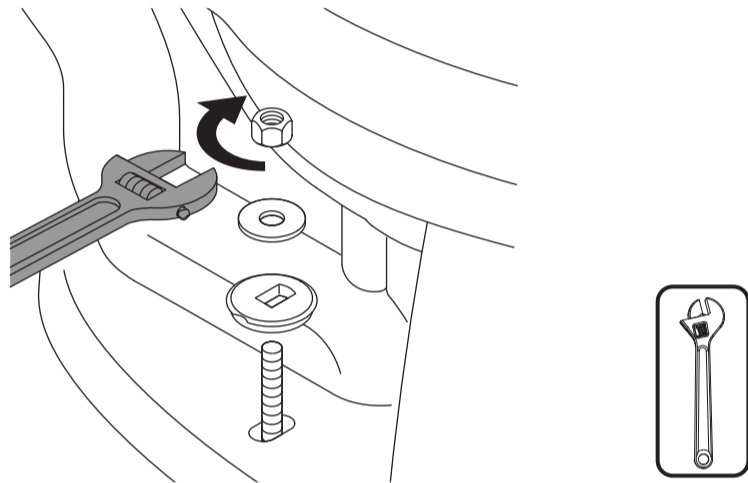

**CAUTION:** Do not over-tighten or damage may occur.

## BOLT CAP INSTALL

- 10** If necessary, cut the excess from the Closet Bolts. Install the Bolt Cap.

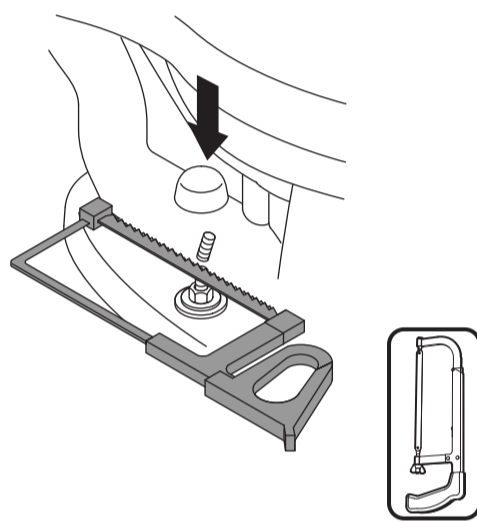

## CONNECT TO WATER SUPPLY

- 11** Flush the water supply line for a few seconds to remove any debris that may enter the Fill Valve. (For new home constructions and/or additions, flush the water supply line for more than a minute to help remove any residual PVC adhesives, solder flux, and/or pipe sealants that were used for the new plumbing.) Install the Supply Line to the Supply Stop. Wrench tighten into position. Turn ON the Supply Stop.

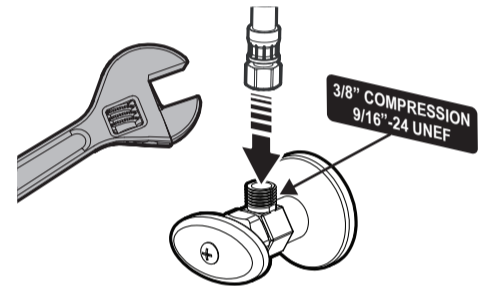

## VERIFY TANK LEVER HANDLE INSTALLATION

- 12** Position the Handle through the opening in the side of the Tank with the Trip Lever facing forward. The square post on the Handle stem should align with the square opening within the Tank as shown below. Secure into position with the included Nut. Hand tighten.

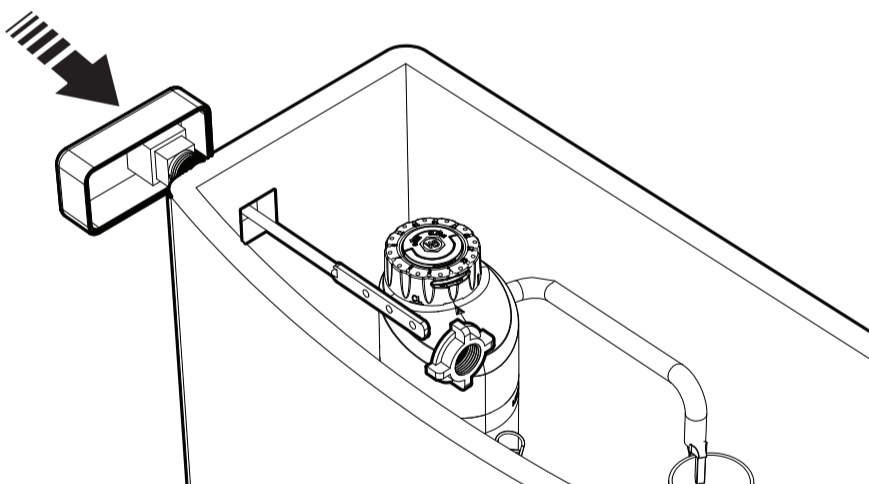

**CAUTION:** Do not over-tighten or damage may occur.

## VERIFY PROPER CHAIN LENGTH

- 14** Attach the Chain from the Flapper to one of the corresponding holes within the Handle Lever. When correctly installed the Flapper should fully seal against the Flush Valve when the Handle is in the resting position, yet open appropriately when the Handle is activated to flush the Toilet. Additional adjustments to the length of the Chain may be required to achieve this.

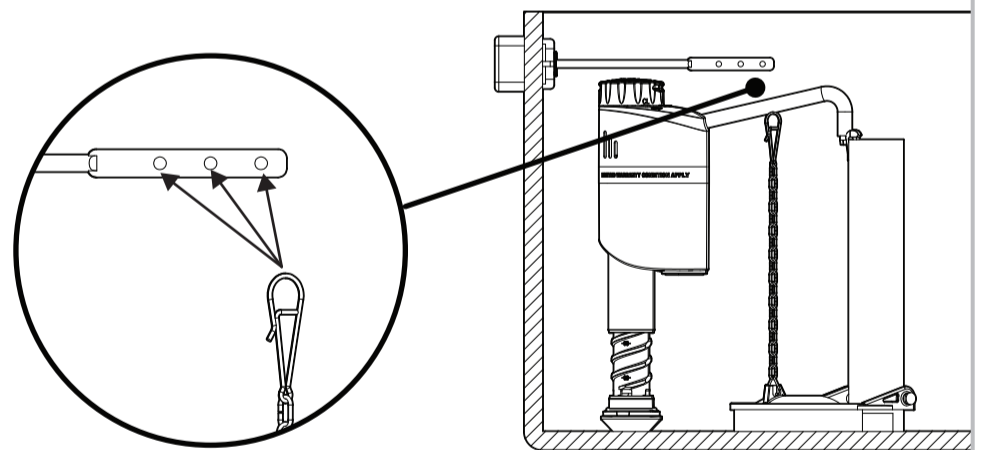

**CAUTION:** Remove the Tape securing the Flapper in position if present.

## TEST FLUSH

- 14** Flush Toilet a few times to check for issues and leaks. Make sure there are NO WATER LEAKS on Bowl or Tank.

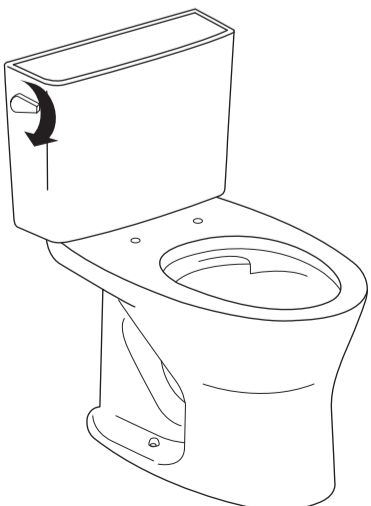

## WATER LEVEL ADJUSTMENT

- 15** The Fill Valve is factory pre-set. If adjustments are required:  
To **increase** the water level, turn the Rotating Dial counterclockwise while holding the body of the Fill Valve to prevent any unnecessary movement.  
To **decrease** the water level, turn the Rotating Dial clockwise while holding the body of Fill Valve to prevent any unnecessary movement.  
*There are 24 marked dots on the Rotating Dial. Each dot represents a level of adjustment in regards to the water level in tank.*

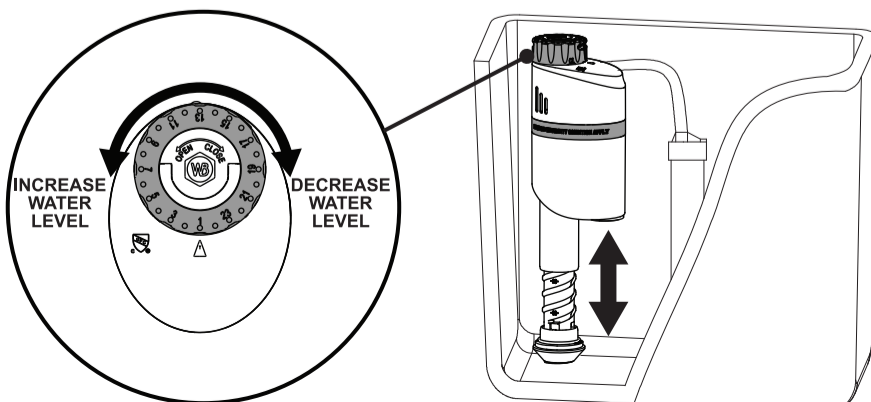

## TANK LID INSTALL

- 16** Place the Tank Lid onto the Tank.



## INSTALL TOILET SEAT

- 17** Install the Toilet Seat using the instructions included within the Toilet Seat packaging.

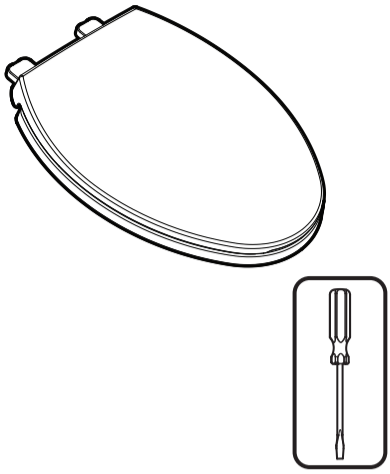

## FLAPPER ADJUSTMENT

This Toilet includes an Adjustable Flapper that allows the installer to adjust the volume of water used per flush. This Adjustable Flapper comes pre-adjusted to use 1.28 gallons / 4.8 liters per flush. If your installation requires a different volume of water per flush, access the underside of the Adjustable Flapper and rotate the adjustment wheel towards the minus symbol (-) for **MORE** water used per flush, or towards the plus symbol (+) for **LESS** water used per flush.

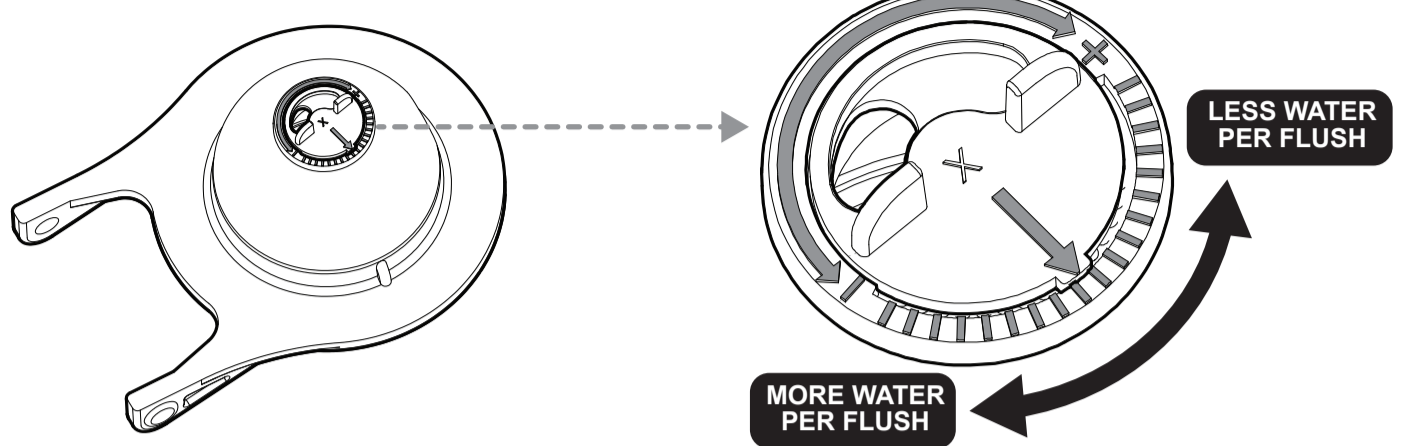

## MAINTENANCE: FILL VALVE FILTER CLEANING

- 1** Turn **OFF** water supplies (A). Lift handle of Filter (B). Rotate Filter counter-clockwise while holding the Rotational Dial stationary (C).

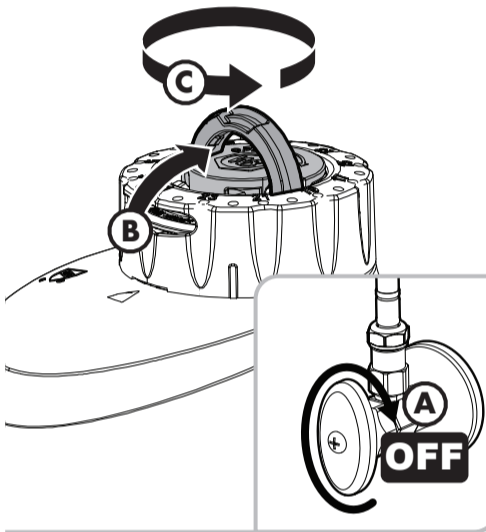

- 2** Once Filter is released, pull upward to remove from the Fill Valve.

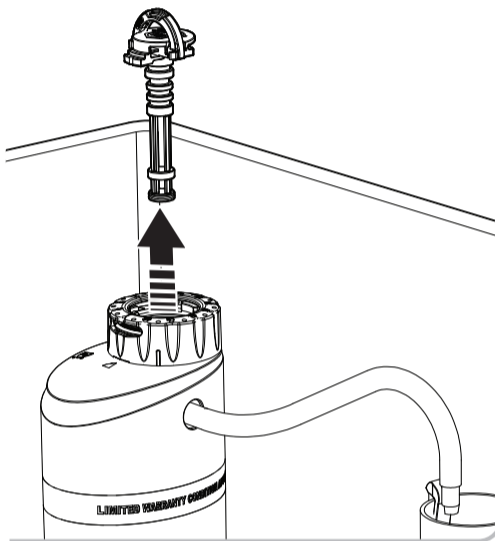

- 3** Clean Filter by rinsing under running water.



- 4** Insert the Filter into the Fill Valve while aligning the Tabs (A). Rotate Filter clockwise while holding the Rotational Dial stationary until Filter locks into position (B). Turn **ON** water supplies (C).

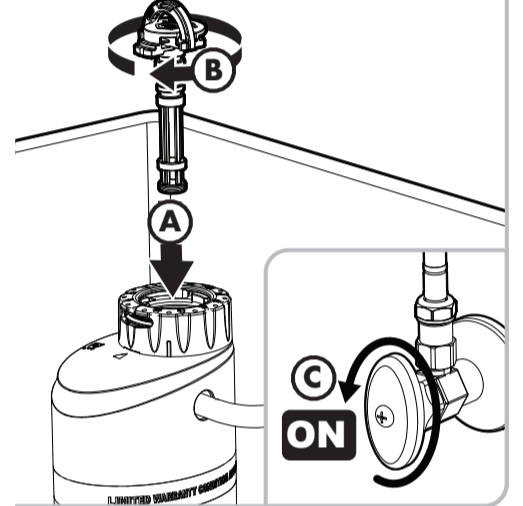

## TROUBLESHOOTING

### Issue: Water level in Tank is too high or too low

*Cause: Fill Valve is not adjusted to the desired position.*

*Solution: Adjust water level by following the "Water Level Adjustment" section.*

### Issue: Fill Valve does not turn ON

*Cause: Water Supply is OFF.*

*Solution: Turn ON Water Supply. If Fill Valve is still not functional, turn OFF Water Supply and clean Filter Screen by following the "Filter Cleaning" section in this manual.*

### Issue: Fill Valve does not turn OFF

*Cause: Refill Tube wasn't installed properly.*

*Solution: Re-install the Refill Tube and ensure that Refill Tube Outlet is above the water level when Tank is full.*

## T-5002 ROUGH-IN DIAGRAM

### COMPLIANCE

ASME A112.19.2/CSA B45.1

cUPC certified

WaterSense certified

ADA compliant

### CONNECTIONS

3/8" Compression Inlet Hose Connection  
\* Included

12" Rough-In to wall

## PRODUCT WARRANTY

PRODUCT	Warranty Period	
	Residential Installation	Commercial Installation
Vitreous China Material	Limited Lifetime	10 Year Limited
Mechanical Components	Limited*	Limited*
Seat	1 Year Limited	1 Year Limited

Speakman will, at its election, repair, replace, or make appropriate adjustment where Speakman's inspection discloses any such defects occurring in normal usage. Damage caused by accident, misuse, or abuse is not covered by this warranty. Improper care and cleaning will void the warranty. Use of Chlorine or chemically related components will void the warranty. Proof of purchase (original sales receipt) must be provided to Speakman with all warranty claims. Speakman is not responsible for removal, installation, labor charges, or other incidental or consequential costs. In no event shall the liability of Speakman exceed the purchase price of the toilet.

\*Mechanical Component Limited Warranty varies based on component affected. Please call 1-800-537-2107 for additional information.

## CALIFORNIA PROPOSITION 65



### CALIFORNIA PROPOSITION 65:

**WARNING:** This product can expose you to chemicals including lead, which is known to the State of California to cause cancer and birth defects or other reproductive harm. For more information go to [www.P65Warnings.ca.gov](http://www.P65Warnings.ca.gov).

Wash hands after installation, repair, or removal of this product.

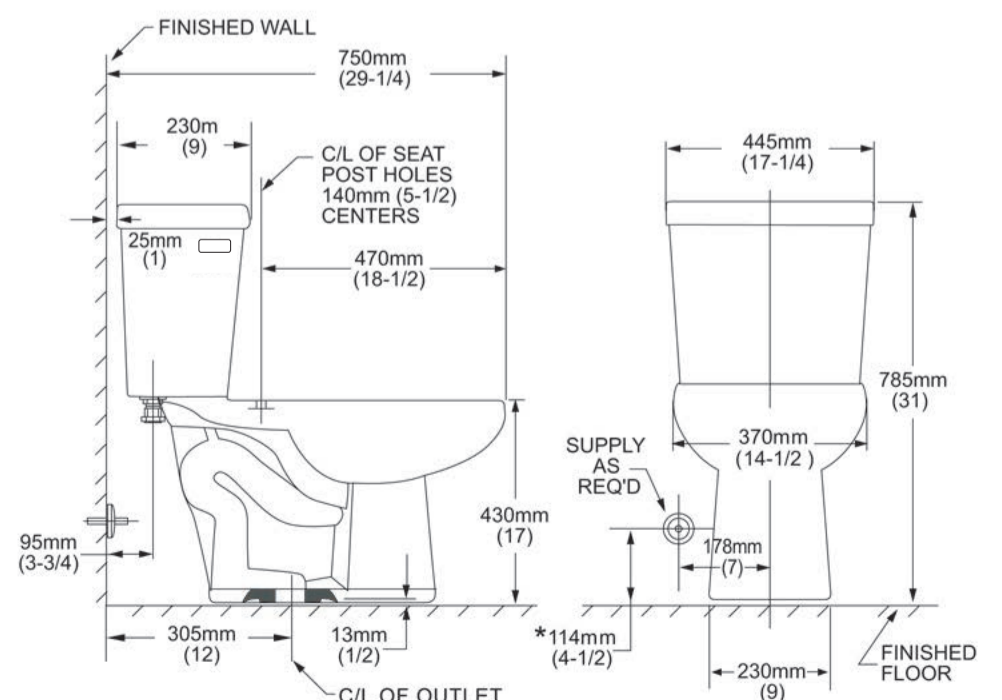

REPAIR PARTS

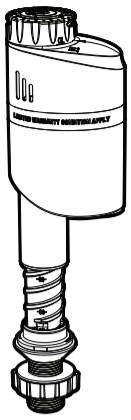

**87751**  
Finale ProSeries  
Fill Valve with Brass Shank

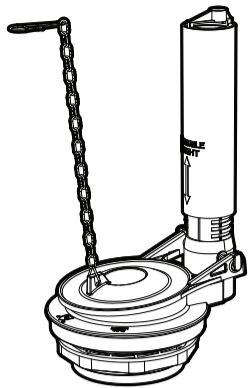

**39741**  
3" Adjustable Flush Valve  
with Adjustable Flapper

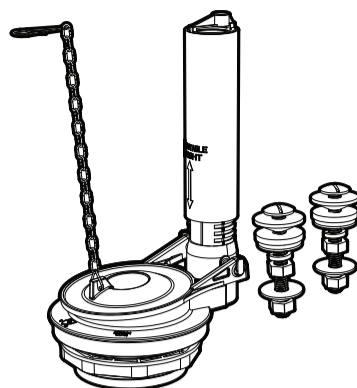

**39740**  
3" Adjustable Flush Valve  
with Adjustable Flapper  
&  
Tank-Bowl Bolt Set

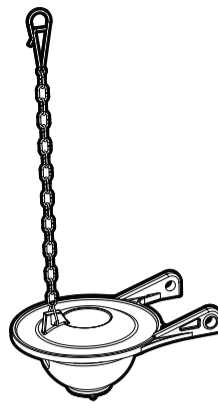

**39744**  
3" Adjustable Flapper

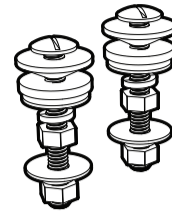

**39742**  
Tank-Bowl Bolt Set

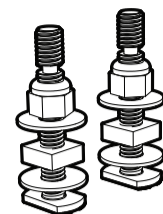

**59449W**  
Brass Closet Bolt Set



**51220**  
Closet Bolt Cap Set

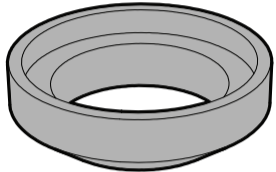

**39750**  
Rubber Molded Spud Gasket

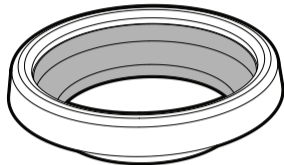

**51499**  
Wax Bowl Gasket

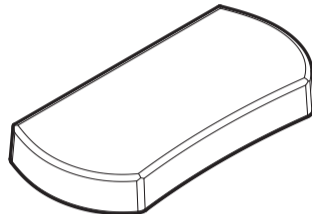

**39745**  
Replacement Tank Lid

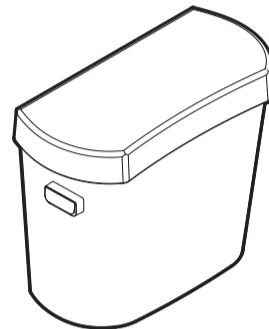

**39702T**  
Left Hand Flush  
Replacement Tank Assembly



**39752**  
Left Hand  
Replacement Flush Handle

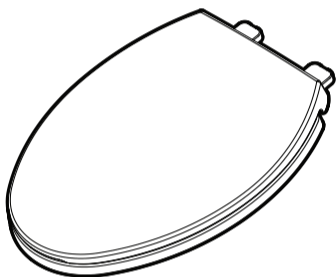

**39710**  
Elongated  
Slow-Close Toilet Seat



**57665**  
16" Toilet Supply Line